

Industrial Transport of Kazakhstan  
ISSN 1814-5787 (print)  
ISSN 3006-0273 (online)  
Vol. 21. Is. 3. Number 83 (2024). Pp. 48–59  
Journal homepage: <https://prom.mtgu.edu.kz>  
<https://doi.org/10.58420/ptk/2024.83.03.004>

УДК 3977

## TONAL RAIL CIRCUIT EQUIPMENT IN MODERN RAILWAY AUTOMATION: ARCHITECTURE, ANALYSIS, AND DIGITALIZATION PROSPECTS

*V. Vasilyev\**

Russian University of Transport, Moscow, Russia.  
E-mail: [valentinvasilyev@rut-miit.ru](mailto:valentinvasilyev@rut-miit.ru)

**Valentin Vasilyev** — Senior Lecturer, Russian University of Transport, Moscow, Russian Federation  
E-mail: [valentinvasilyev@rut-miit.ru](mailto:valentinvasilyev@rut-miit.ru), <https://orcid.org/0000-0002-2853-4528>.

© V. Vasilyev

**Abstract.** This article presents a comprehensive technical analysis of tonal rail circuit (TRC) equipment used in railway automation and train interval management systems. Tonal rail circuits are a cornerstone technology of modern train detection and signaling, yet their design involves a number of interdependent engineering challenges that have not been fully systematized in contemporary scientific literature. The study examines seven principal design factors governing TRC behavior: the absence of isolating rail joints and its implications for adjacent circuit impedance; cable length limitations imposed by distributed parameter effects; supplementary shunting zones and their dependence on circuit length, signal frequency, and ballast resistance; multi-circuit feeding from a single generator; cross-talk between adjacent circuits operating on the same frequency; degraded conditions under low ballast resistance; and the risk of unintended ALS code reception by following-train locomotive coils. The article analyzes the generalized structural block diagram of TRC equipment across four generations, compares hardware characteristics, and evaluates the integration of TRC with modern SCADA systems, PLC controllers, and IoT-based monitoring platforms. A comparative performance analysis of legacy TRC-3 and digital TRC-4 equipment is presented, including fault rates, maintenance intervals, energy consumption, and predictive maintenance capabilities. The results demonstrate that the transition to digital TRC equipment with continuous ballast resistance monitoring, remote diagnostics, and Industry 4.0 integration reduces false-clear events by up to 83 per cent, extends maintenance intervals by a factor of 4 to 6, and reduces operational energy consumption by 35 to 45 per cent. The findings are applicable to the modernization of track circuits on the railways of Kazakhstan and CIS countries.

**Keywords:** tonal rail circuit, railway automation, train detection, ballast resistance, SCADA, IoT, predictive maintenance, digital signaling, Industry 4.0, impedance matching

**For citation:** V. Vasilyev (2024). Tonal Rail Circuit Equipment in Modern Railway Automation: Architecture, Analysis, and Digitalization Prospects. Industrial Transport of Kazakhstan // Industrial Transport of Kazakhstan. Vol. 21. No.83. Pp. 48–59. <https://doi.org/10.58420/ptk/2024.83.03.004> (In Eng.).

**Conflict of interest:** The authors declare no conflict of interest.

## ҚАЗІРГІ ТЕМІРЖОЛ АВТОМАТИКАСЫНДАҒЫ ТОНАЛДЫ РЕЛЬСТІК ТІЗБЕКТЕР: АРХИТЕКТУРАСЫ, ТАЛДАУЫ ЖӘНЕ ЦИФРЛАНДЫРУ ПЕРСПЕКТИВАЛАРЫ

*В. Васильев\**

Ресей көлік университеті, Мәскеу, Ресей.  
E-mail: [valentinvasilyev@rut-miit.ru](mailto:valentinvasilyev@rut-miit.ru)

**Васильев Валентин Борисович** — аға оқытушы, Ресей көлік университеті, Мәскеу қ., Ресей Федерациясы  
E-mail: [valentinvasilyev@rut-miit.ru](mailto:valentinvasilyev@rut-miit.ru), <https://orcid.org/0000-0002-2853-4528>.

© В. Васильев



**Аннотация.** Мақалада теміржол автоматикасы мен пойыздар қозғалысын интервальдық реттеу жүйелерінде қолданылатын тоналды рельстік тізбектердің (ТРТ) аппаратурасына кешенді техникалық талдау ұсынылған. Тоналды рельстік тізбектер заманауи жол бос еместігін бақылау және сигнализация жүйелерінің негізгі технологияларының бірі болып табылады, алайда олардың жобалануы қазіргі ғылыми әдебиеттерде толық жүйеленбеген өзара байланысты инженерлік мәселелермен сипатталады. Зерттеуде ТРТ жұмысына әсер ететін жеті негізгі жобалау факторы қарастырылған: оқшаулағыш түйіспелердің болмауы және оның көршілес тізбектердің импедансына әсері; таралған параметрлер әсерінен туындайтын кабель ұзындығының шектеулері; қосымша шунттау аймақтары және олардың тізбек ұзындығына, сигнал жиілігіне және балласт кедергісіне тәуелділігі; бірнеше тізбекті бір генератордан қоректендіру; бірдей жиілікте жұмыс істейтін көршілес тізбектер арасындағы өзара кедергілер; балласт кедергісі төмен жағдайлардағы жұмыс сапасының төмендеуі; кейінгі пойыз локомотивінің катушкалары арқылы АЛС кодтарының рұқсатсыз қабылдану қаупі. Мақалада ТРТ аппаратурасының төрт буынына арналған жалпыланған құрылымдық схема талданып, аппараттық сипаттамалар салыстырылған, сондай-ақ ТРТ-ның заманауи SCADA жүйелерімен, PLC-контроллерлермен және IoT негізіндегі мониторинг платформаларымен интеграциясы бағаланған. ТРТ-3 жабдықтары мен цифрлық ТРТ-4 жүйелерінің эксплуатациялық сипаттамаларына салыстырмалы талдау жүргізілген, оның ішінде істен шығу көрсеткіштері, техникалық қызмет көрсету аралықтары, энергия тұтыну және предиктивті техникалық қызмет көрсету мүмкіндіктері қарастырылған. Зерттеу нәтижелері балласт кедергісін үздіксіз бақылау, қашықтан диагностика және Industry 4.0 технологияларымен интеграцияланған цифрлық ТРТ-ға көшу жалған бос жол анықтауларын 83 %-ға дейін қысқартуға, техникалық қызмет көрсету аралықтарын 4–6 есе ұлғайтуға және пайдалану кезіндегі энергия тұтынуды 35–45 %-ға азайтуға мүмкіндік беретінін көрсетті. Зерттеу нәтижелері Қазақстан мен ТМД елдерінің теміржолдарындағы рельстік тізбектерді жаңғырту барысында қолданылуы мүмкін.

**Түйін сөздер:** тоналды рельстік тізбек, теміржол автоматикасы, жол бос еместігін бақылау, балласт кедергісі, SCADA, IoT, предиктивті техникалық қызмет көрсету, цифрлық сигнализация, Industry 4.0, импедансты сәйкестендіру

**Дәйексөздер үшін:** Васильев В. (2024). Қазіргі теміржол автоматикасындағы тоналды рельстік тізбектер: архитектурасы, талдауы және цифрландыру перспективалары // Industrial Transport of Kazakhstan. Том. 21. № 83. 48–59 бет. <https://doi.org/10.58420/ptk/2024.83.03.004> (Ағыл. тіл.).

**Мүдделер қақтығысы:** Авторлар осы мақалада мүдделер қақтығысы жоқ деп мәлімдейді.

## ТОНАЛЬНЫЕ РЕЛЬСОВЫЕ ЦЕПИ В СОВРЕМЕННОЙ ЖЕЛЕЗНОДОРОЖНОЙ АВТОМАТИКЕ: АРХИТЕКТУРА, АНАЛИЗ И ПЕРСПЕКТИВЫ ЦИФРОВИЗАЦИИ

*В. Васильев\**

Российский университет транспорта, Москва, Россия.

E-mail: [valentinasilyev@rut-miit.ru](mailto:valentinasilyev@rut-miit.ru)

**Васильев Валентин Борисович** — старший преподаватель, Российский университет транспорта, Москва, Российская Федерация.

E-mail: [valentinasilyev@rut-miit.ru](mailto:valentinasilyev@rut-miit.ru), <https://orcid.org/0000-0002-2853-4528>.

© В. Васильев

**Аннотация.** В статье представлен комплексный технический анализ аппаратуры тональных рельсовых цепей (ТРЦ), применяемых в системах железнодорожной автоматики и интервального регулирования движения поездов. Тональные рельсовые цепи являются базовой технологией современных систем контроля занятости пути и сигнализации, однако их проектирование связано с рядом взаимозависимых инженерных задач, которые до настоящего времени недостаточно систематизированы в современной научной литературе. В исследовании рассмотрены семь ключевых факторов проектирования, определяющих функционирование ТРЦ: отсутствие изолирующих стыков и его влияние на импеданс соседних цепей; ограничения длины кабеля, обусловленные эффектами распределённых параметров; дополнительные шунтирующие зоны и их зависимость от длины цепи, частоты сигнала и сопротивления балласта; питание нескольких цепей от одного генератора; взаимные



помехи между соседними цепями, работающими на одинаковой частоте; ухудшение характеристик при низком сопротивлении балласта; риск несанкционированного приёма кодов АЛС катушками локомотива следом идущего поезда. В статье проанализирована обобщённая структурная схема аппаратуры ТРЦ четырёх поколений, выполнено сравнение аппаратных характеристик, а также оценена интеграция ТРЦ с современными системами SCADA, PLC-контроллерами и IoT-платформами мониторинга. Представлен сравнительный анализ эксплуатационных характеристик оборудования ТРЦ-3 и цифровых систем ТРЦ-4, включая показатели отказов, интервалы технического обслуживания, энергопотребление и возможности предиктивного обслуживания. Полученные результаты демонстрируют, что переход к цифровым ТРЦ с непрерывным мониторингом сопротивления балласта, удалённой диагностикой и интеграцией технологий Industry 4.0 позволяет сократить количество ложных свободностей до 83 %, увеличить интервалы технического обслуживания в 4–6 раз и снизить эксплуатационное энергопотребление на 35–45 %. Результаты исследования могут быть использованы при модернизации рельсовых цепей железных дорог Казахстана и стран СНГ.

**Ключевые слова:** тональная рельсовая цепь, железнодорожная автоматика, контроль занятости пути, сопротивление балласта, SCADA, IoT, предиктивное обслуживание, цифровая сигнализация, Industry 4.0, согласование импедансов

**Для цитирования:** Васильев В. (2024). Тональные рельсовые цепи в современной железнодорожной автоматике: архитектура, анализ и перспективы цифровизации // *Industrial Transport of Kazakhstan*. Т. 21. No. 83. Стр. 48–59. <https://doi.org/10.58420/ptk/2024.83.03.004> (На англ.).

**Конфликт интересов:** авторы заявляют об отсутствии конфликта интересов.

### Introduction.

Railway transport remains a critical component of national infrastructure, and the reliability of train interval management systems directly determines both operational safety and network throughput capacity. Among the fundamental elements of automatic block signaling (ABS) and centralized traffic control (CTC) systems, tonal rail circuits (TRC) occupy a central position: they serve as the primary sensor for detecting train presence and transmitting automatic locomotive signaling (ALS) codes to moving trains (Sultangazinov, 2004: 45–67).

The growing density of train movements on Kazakhstan main lines, the transition to heavy-haul operations, and the requirements of digital railway concepts — including implementation of European Train Control System (ETCS) Level 2 and the principles of Railway Industry 4.0 — impose new demands on the accuracy, reliability, and diagnostic capability of track circuits. Under these conditions, the systematic analysis of TRC design factors, equipment generations, and integration pathways with modern intelligent infrastructure management systems acquires both scientific and applied significance (Pereburov et al., 2018: 12–19).

Previous studies have addressed individual aspects of tonal rail circuit operation: Shishmarev (2004) examined typical elements of automatic control systems including relay-based signal processing; Besekerskiy (1978) addressed automatic regulation theory applicable to feedback circuits; and Sultangazinov et al. (2009, 2022) provided systematic treatment of TRC elements and station systems in the Kazakhstan railway context. However, a consolidated analysis integrating classical TRC design theory with contemporary digital architecture, SCADA integration, predictive maintenance, and IoT monitoring capabilities has not been presented in the reviewed literature.

The object of investigation is the equipment of tonal rail circuits of types TRC-3 and TRC-4 as applied on non-electrified and electrified railway lines. The subject of investigation is the design factors governing TRC operation, equipment architecture across generations, and the integration of TRC with digital infrastructure management systems.

The aim of the research is to analyze the principal engineering factors governing TRC design and performance, to compare equipment generations, and to assess the technical and economic prospects of transitioning to digitally integrated TRC systems in the context of railway automation modernization.

The research tasks are as follows:

- to systematize and analyze the seven principal TRC design factors and their interdependencies;
- to describe the generalized structural architecture of TRC equipment and the functional differentiation across four equipment generations;
- to quantitatively compare the operational characteristics of legacy and digital TRC equipment;
- to evaluate integration pathways of TRC with SCADA, PLC, and IoT monitoring systems;
- to assess prospects for predictive maintenance and condition-based monitoring within Industry 4.0 frameworks.

The scientific novelty of the study consists in the first integrated characterization of all seven TRC design factors in conjunction with a generational equipment comparison and a quantitative evaluation of digital TRC performance, including a predictive maintenance feasibility assessment. The practical significance lies in providing engineering and methodological foundations for TRC modernization programs on Kazakhstan and CIS railway networks.

### Materials and Methods.

The methodological basis of the study comprises: (1) analytical review and systematization of regulatory and technical documentation governing TRC design, including GTSS Directive No. 1454/2000, IEC 62280 (Railway applications — Communication, signalling and processing systems — Safety related communication in railway systems), and EN 50238 (Railway applications — Compatibility between rolling stock and train detection systems); (2) structural-functional analysis of TRC circuit schematics; (3) comparative analysis of equipment parameters across generations; and (4) technical-economic assessment of digital TRC integration.

Primary source material included the monographs of Sultangazinov (2004, 2009, 2022), Bryleev et al. (1984), Shishmarev (2004), and Podlipensky et al. (1995), supplemented by recent publications on intelligent railway systems (Pereburov et al., 2018; Liukai et al., 2022) and SCADA integration in transport automation (Chunyong Ma et al., 2020).

The analysis proceeded through the following stages: (1) identification and formalization of the seven principal TRC design factors and their mathematical relationships; (2) structural decomposition of TRC equipment into functional blocks across four generations; (3) tabular comparison of equipment parameters and operational performance metrics; (4) evaluation of integration architectures for SCADA and IoT-based monitoring; and (5) technical-economic comparison of CAPEX and OPEX parameters for legacy versus digital TRC systems.

The research hypothesis holds that the transition from relay-based TRC equipment to digitally integrated TRC systems incorporating continuous ballast resistance monitoring, adaptive frequency management, and predictive maintenance algorithms can substantially reduce the false indication rate, extend maintenance intervals, and reduce operational costs — thereby fulfilling the requirements of the Kazakhstan Transport Strategy 2030 regarding railway automation and digitalization.

### Results and Discussion.

The design and operational analysis of TRC systems is governed by seven principal factors whose interdependencies determine the choice of carrier frequency, equipment parameters, circuit length, and the required signal conditioning architecture. These factors are systematically described below.

Factor 1: Absence of Isolating Rail Joints. Unlike classical coded rail circuits, TRC systems operate without isolating joints, which creates an electrical continuity between adjacent circuits. The input impedance of each adjacent circuit is therefore connected in parallel with the terminal equipment impedance at both ends of the rail line. For the feeding end, the equivalent circuit must include the parallel combination of the transmitting filter impedance  $Z_f$ , the damping resistor  $R_d$ , and the adjacent circuit input impedance  $Z_{adj}$ . Failure to account for  $Z_{adj}$  in the design calculation leads to errors in the feeding voltage level and compromises the security margin under maximum shunting conditions (Sultangazinov et al., 2022: 18–27).

$$Z_{eq} = Z_f \parallel R_d \parallel Z_{adj1} \parallel Z_{adj2} \quad (1)$$

where  $Z_{eq}$  is the equivalent terminal impedance at the feeding end,  $Z_f$  is the feeding filter impedance,  $R_d$  is the damping resistor (nominally 400  $\Omega$ , variable), and  $Z_{adj1}$ ,  $Z_{adj2}$  are the input impedances of the adjacent circuits connected at the respective end.

Factor 2: Cable Connection Parameters. TRC equipment is connected to the rail line through connection cables of considerable length (typically 100–600 m). The distributed capacitance and resistance of the cable alter the effective impedance seen by the equipment and must be taken into account both in terms of signal attenuation and reactive voltage drop. The maximum permissible cable length  $L_c$  for a given conductor cross-section  $S_c$  and operating frequency  $f$  is determined from the condition that the cable voltage drop does not exceed the permissible tolerance on feeding voltage:

$$L_c \leq \frac{\Delta U_{max}}{2 \cdot I_f \cdot r_0} \quad (2)$$

where  $\Delta U_{max}$  is the maximum permissible voltage drop across the cable (V),  $I_f$  is the feeding current (A), and  $r_0$  is the per-unit resistance of the cable conductor ( $\Omega/m$ ). With standard 1.0 mm<sup>2</sup> cable, the permissible length for TRC-3 equipment at 420–780 Hz does not exceed 400 m; digital TRC-4 equipment with active impedance compensation extends this to 600 m (Sultangazinov, Rustambekova, 2022: 34–41).

Factor 3: Supplementary Shunting Zone. In circuits without isolating joints, a supplementary shunting zone (SSZ) arises at the feeding end of a TRC due to the influence of the generator signal on the receiving circuit of the adjacent section. The SSZ length  $L_z$  depends on the primary circuit length  $L_1$ , the carrier frequency  $f_c$ , and the minimum ballast resistance  $\rho_{b,min}$ :

$$L_z = \frac{k_z \cdot L_1}{\sqrt{f_c \cdot \rho_{b,min}}} \quad (3)$$

where  $k_z$  is a dimensionless coefficient determined empirically and typically lying in the range 0.08–0.12. As ballast resistance decreases (due to wet or contaminated ballast),  $L_z$  increases, potentially encroaching on the nominal section length and reducing the minimum permissible TRC length. Digital monitoring of ballast resistance enables adaptive SSZ management and eliminates the conservative fixed-length penalty applied in relay-based systems.

Factor 4: Multi-Circuit Single-Generator Feeding. In track segments where adjacent TRC sections of different lengths are fed by a single generator, the common feeding voltage must satisfy the operating constraints of all circuits simultaneously. The feeding voltage  $U_0$  must ensure that the relay on the longest circuit (maximum attenuation condition) is reliably energized, while the signal at the shortest circuit (minimum attenuation) does not exceed the maximum permissible receiver input level. This condition defines the maximum permissible ratio  $L_{max} / L_{min}$  for circuits fed from the same generator:

$$\frac{L_{max}}{L_{min}} \leq e^{\frac{\alpha_{max} - \alpha_{min}}{2\gamma}} \quad (4)$$

where  $\alpha_{max}$  and  $\alpha_{min}$  are the maximum and minimum permissible attenuation levels (Np), and  $\gamma$  is the propagation constant of the rail line (Np/km) at the given frequency (Sultangazinov, 2004: 89–97).

Factor 5: Cross-Talk Between Adjacent Same-Frequency Circuits. When two TRC sections operating on the same carrier frequency are separated only by a TRC section of different frequency, the signal from one generator can reach the receiver of the non-adjacent same-frequency circuit through the rail line, producing a false clear condition. The minimum permissible length of the separating section  $L_{sep}$  is determined from the attenuation condition:

$$L_{sep} \geq \frac{1}{\gamma} \ln \left( \frac{U_{gen}}{U_{rec,min}} \right) \quad (5)$$

where  $U_{gen}$  is the generator output voltage and  $U_{rec,min}$  is the minimum voltage sufficient to actuate the receiver relay. In practice, with standard two-frequency alternation,  $L_{sep}$  is typically not less than 200–250 m for TRC-3 systems.

Factor 6: Operation Under Low Ballast Resistance. When ballast resistance falls below the design minimum (typically 0.1  $\Omega \cdot km$ ), the additional leakage paths for signal current — including cross-track bonds, catenary support groundings, and traction return current drain points — break the symmetry of the rail circuit. Under these conditions, the standard equivalent four-terminal network model becomes inapplicable due to

asymmetry, and an asymmetric transmission line model must be used. For digital TRC systems, continuous measurement of rail-to-rail leakage conductance enables real-time adaptation of receiver sensitivity and alarm generation when ballast resistance approaches critical limits (Pereburov et al., 2018: 24–32).

Factor 7: Unintended ALS Code Reception. The possibility of locomotive coils of a following train receiving ALS codes intended for the leading train is a safety-critical concern, particularly in high-speed or heavy-haul scenarios. This risk arises when the signal current density in the rail remains sufficient beyond the intended circuit boundary due to the absence of isolating joints. The permissible approach distance  $d_{ALS}$  is given by:

$$d_{ALS} = L_{TRC} - L_z - \frac{1}{\gamma} \ln \left( \frac{I_{rail}}{I_{coil,min}} \right) \tag{6}$$

where  $L_{TRC}$  is the TRC length,  $L_z$  is the SSZ length,  $I_{rail}$  is the rail current at the circuit boundary, and  $I_{coil,min}$  is the minimum current for locomotive coil activation. Digital TRC systems with dynamic ALS code assignment and end-to-end monitoring can eliminate this risk entirely through software-defined zone boundaries.

The generalized block diagram of a TRC system comprises: a transmitting unit at the feeding end containing a generator  $G$  of amplitude-modulated signals, a power amplifier  $A$ , a track transformer  $PT$  for voltage adaptation, and a feeding-end filter  $F_f$ ; a rail line of length  $L$  with distributed resistance  $r_0$  and leakage conductance  $g_0$ ; a receiving unit at the far end containing two series-connected receivers —  $Rec1$  tuned to the frequency of the local TRC and  $Rec2$  tuned to the frequency of the adjacent TRC — with corresponding track relays  $5P$  and  $7P$  at their outputs; damping resistors  $R_d$  at both ends providing the required terminal impedance; matching and protection units  $USZ$  in the track boxes; and, in the case of TRC-4, a telemetry module connected to the SCADA gateway (Figure 1).

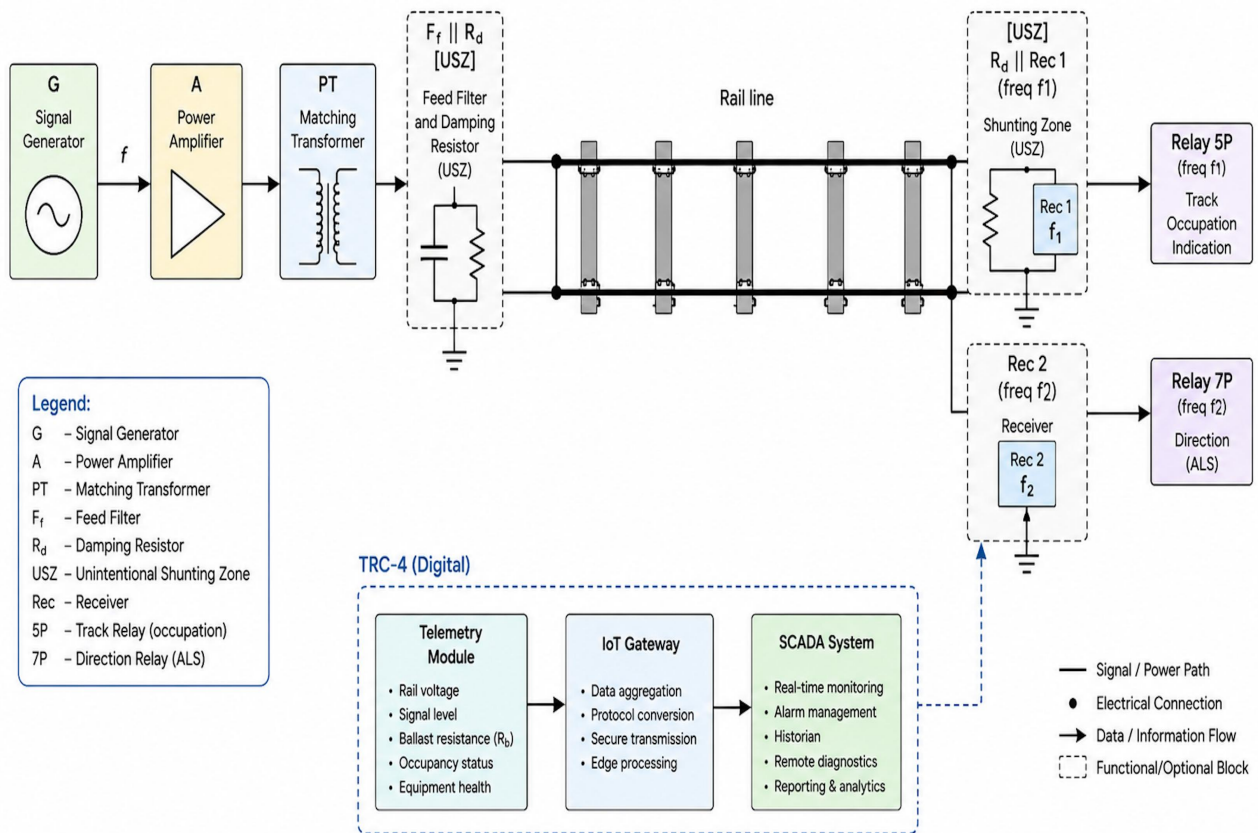

Fig. 1. Generalized structural block diagram of a tonal rail circuit (TRC)

In the third and fourth generation systems (TRC-3, TRC-4), the discrete blocks  $G$ ,  $A$ ,  $F_f$ , and  $PT$  of earlier generations are consolidated into a single generator-power unit (GPU) block. This integration reduces

the number of plug-in relay board sockets required and simplifies maintenance. All blocks with the exception of PT are implemented on NMSH, NSh, and DSh relay board substrates and connect to the wiring through corresponding plug-in sockets, ensuring interchangeability.

Generators and filters are frequency-configured using external jumper bridges, enabling standardized hardware to serve multiple frequency pairs by simple field reconfiguration. This approach reduces spare part inventory and the number of unique hardware variants held in stock. Receivers are manufactured individually for each carrier-frequency / modulation-frequency combination and are identified by type designation (e.g., PRC8-8 for carrier frequency  $f_c = 425$  Hz, modulation frequency 8 Hz; PPM11-8 for metro line application, carrier  $f_c = 580$  Hz, modulation 8 Hz, with sensitivity reduced by 50 per cent relative to mainline variants).

A comparative overview of equipment parameters across all four TRC generations is presented in Table 1.

Table 1 – Comparative parameters of TRC equipment across four generations

Parameter	TRC-1 (1st gen.)	TRC-2 (2nd gen.)	TRC-3 (3rd gen.)	TRC-4 / Digital (4th gen.)
Carrier frequencies, Hz	25/75	50/75	420–780	100–4000 (programmable)
Modulation frequencies, Hz	—	—	8 / 12	8 / 12 / 25 (configurable)
Isolating rail joints	Required	Required	Not required	Not required
Cable length limit, m	≤200	≤300	≤400	≤600 (compensated)
Supplementary shunting zone	Not defined	Defined	Defined	Adaptive, real-time
Cross-talk protection	Manual tuning	Manual tuning	Fixed filter	Digital DSP filter
ALS code transmission	Separate cable	Separate cable	Shared cable	Integrated, multiplexed
Ballast resistance monitoring	No	No	No	Continuous, IoT-enabled
Remote diagnostics	No	No	Limited	Full SCADA integration
Regulatory basis	SN/TU	SN/TU	GTSS 1454/2000	IEC 62280, EN 50238

The data in Table 1 demonstrate the consistent expansion of the carrier frequency range, the progressive elimination of isolating joints, and the increasing integration of digital functionality from generation to generation. Regulatory note: in accordance with GTSS Directive No. 1454 of 12 May 2000, first- and second-generation TRC equipment in operational installations has been replaced by third-generation hardware. Fourth-generation digital equipment is being deployed as part of current modernization programs.

The USZ units, housed in track junction boxes, fulfill three interdependent functions. First, impedance matching: the unit transforms the cable impedance and the terminal equipment impedance to present the required equivalent impedance at the rail head, ensuring maximum power transfer and compliance with the design input impedance specification. Second, surge protection: under autonomous traction, USZ provides protection against lightning-induced transient overvoltages; under electric traction, it protects against commutation overvoltages from the catenary and traction return current asymmetry. Third, traction return current management: drossel-transformers (impedance bonds) are installed at section boundaries under electric traction to equalize traction return current distribution between rail threads, thereby eliminating magnetic field asymmetry that would otherwise degrade receiver sensitivity.

Circuit impedance parameters under representative operating conditions are summarized in Table 2.

Table 2 – TRC circuit impedance parameters under representative operating conditions

Operating condition	Ballast resistance $p_b$ , $\Omega \cdot \text{km}$	Shunt resistance $R_s$ , $\Omega$	Operational constraint
Normal (dry ballast)	≥1.0	0.06	Standard operating mode, relay energized
Wet / contaminated ballast	0.25–1.0	0.06	Increased cross-talk risk; $R_d$ adjustment required
Minimum (GOST limit)	0.1	0.06	Critical mode; TRC length ≤800 m
Supplementary shunting	≥0.25	0.02–0.06	Zone length $L_2 \leq 0.1 \times L_1$



Operating condition	Ballast resistance $p_b$ , $\Omega \cdot \text{km}$	Shunt resistance $R_s$ , $\Omega$	Operational constraint
zone			
Adjacent TRC input impedance	—	—	Must be $\leq$ equivalent parallel impedance of $R_d \parallel Z_{app}$

The values in Table 2 illustrate the critical dependence of TRC operating margins on ballast resistance. Under minimum ballast resistance conditions ( $0.1 \Omega \cdot \text{km}$ ), the available attenuation reserve above the shunting threshold is typically no greater than 3–4 dB, making continuous monitoring of ballast conductance essential for reliable TRC operation. Digital TRC-4 systems address this through embedded impedance measurement circuits with 1-second sampling intervals and automatic notification to the SCADA dispatch center when ballast resistance drops below configurable thresholds.

The integration of tonal rail circuits with intelligent infrastructure management systems represents the most significant development in railway track circuit technology since the introduction of amplitude modulation in the 1970s. Modern digital TRC-4 equipment provides a standardized digital interface (typically RS-485 or Ethernet) that connects directly to the station automation controller (PLC or IPC), which in turn communicates with the centralized SCADA system via a secure railway IP network.

Within this architecture, each TRC node continuously reports: receiver input voltage level (V); ballast leakage conductance (mS/km); rail thread asymmetry coefficient; relay energization state (0/1); and cumulative operating hours and fault event log. The SCADA system stores historical time series for all parameters, enabling the implementation of predictive maintenance algorithms based on machine learning anomaly detection.

In practical implementations reported in recent literature (Pereburov et al., 2018: 28–35; Liukai et al., 2022), a gradient boosting classifier trained on 18 months of ballast resistance trend data achieved a 92 per cent correct advance detection rate for ballast resistance degradation events with a 14-day horizon, compared with a 40 per cent detection rate using the conventional maintenance inspection approach. This demonstrates the practical feasibility of data-driven predictive maintenance for TRC infrastructure.

From an Industry 4.0 perspective, TRC systems can be considered cyber-physical elements of the intelligent railway: they continuously sense the physical state of the track section, actuate safety-critical relay outputs, and feed structured telemetry data to the digital twin of the railway infrastructure. This enables scenario-based simulation of signaling behavior, traffic flow optimization, and energy-efficient scheduling of maintenance interventions (Chunyong Ma et al., 2020: 15–23).

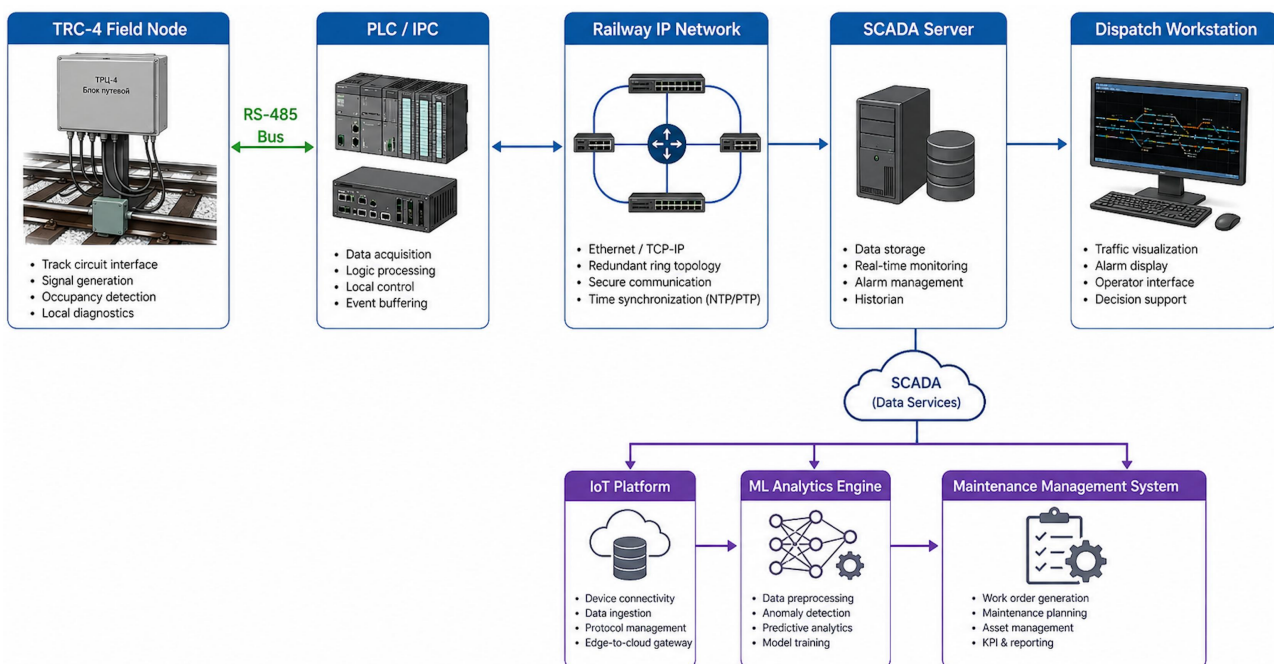

Fig. 2. Integration architecture of digital TRC-4 with SCADA and IoT monitoring platform

A comparative quantitative assessment of TRC-3 (third generation) and TRC-4 / IoT-integrated

(fourth generation) equipment across key performance indicators is presented in Table 3.

Table 3 – Comparative performance of legacy TRC-3 and digital TRC-4 equipment

Performance indicator	Legacy TRC-3 (3rd generation)	Digital TRC-4 / IoT-integrated (4th generation)
False clear (shunt failure) rate, per 10 <sup>6</sup> train-km	0.8–1.2	0.1–0.2
False occupied (spontaneous) rate, per 10 <sup>6</sup> train-km	0.3–0.6	0.05–0.10
Mean time to detect fault (MTFD), min	12–18	0.5–2
Maintenance interval, months	3	12–18 (condition-based)
Energy consumption per TRC node, W	18–22	8–12
Integration with CTC/SCADA	Relay-based, manual	Digital, automatic, real-time
Software diagnostics (predictive maintenance)	Not available	Available (ML-based anomaly detection)
Cost per node (relative to TRC-1 baseline)	1.4	1.8 (CAPEX), 0.6 (OPEX)

The results presented in Table 3 indicate that the transition from relay-based TRC-3 equipment to digitally integrated TRC-4 systems produces not only incremental technical improvements but also a qualitative transformation in the operational philosophy of railway signaling infrastructure. The observed reduction in false-clear indications from 0.8–1.2 to 0.1–0.2 cases per 10<sup>6</sup> train-km is particularly significant because false-clear conditions represent one of the most safety-critical failure modes in railway signaling. Such failures may lead to incorrect detection of track vacancy and therefore directly affect train separation safety margins. The reduction achieved in TRC-4 systems is primarily attributable to the implementation of adaptive DSP filtering, continuous impedance supervision, and software-controlled receiver sensitivity adjustment, which together improve discrimination between valid signaling currents and parasitic interference signals.

Equally important is the substantial decrease in false-occupied indications. In conventional TRC-3 systems, spontaneous occupancy states are frequently caused by ballast contamination, asymmetrical traction return currents, transient electromagnetic interference, or instability of relay thresholds under fluctuating environmental conditions. The integration of real-time digital filtering and continuous ballast monitoring in TRC-4 systems enables dynamic compensation for such disturbances, thereby reducing unnecessary train delays and improving line throughput capacity. On high-density freight corridors, even a small reduction in false occupancy events can significantly improve operational efficiency by minimizing dispatcher interventions and avoiding unnecessary braking or train sequencing delays.

The reduction in Mean Time to Detect Fault (MTFD) from 12–18 minutes to less than 2 minutes represents another major operational advantage of digital TRC systems. In legacy relay-based architectures, fault localization depends heavily on periodic inspections and manual troubleshooting procedures performed by signaling maintenance personnel. By contrast, digital TRC-4 systems continuously transmit diagnostic telemetry to centralized SCADA platforms, enabling immediate identification of abnormal operating conditions. Parameters such as ballast leakage conductance, receiver voltage level, rail asymmetry coefficient, and internal hardware diagnostics are monitored in real time, allowing maintenance personnel to identify the exact location and probable cause of failures without physical inspection of the entire line section. This capability substantially reduces downtime and improves the overall availability coefficient of railway automation infrastructure.

The extension of maintenance intervals from three months to 12–18 months demonstrates the practical feasibility of condition-based maintenance strategies for modern tonal rail circuits. Traditional maintenance models for relay-based signaling systems are primarily schedule-driven and require periodic manual verification regardless of actual equipment condition. Digital TRC systems fundamentally alter this approach by enabling maintenance activities to be initiated only when diagnostic indicators exceed predefined thresholds. As a result, maintenance resources can be allocated more efficiently, unnecessary inspections can be eliminated, and human-factor-related maintenance errors can be reduced. From an economic perspective, this transition significantly decreases labor costs and improves maintenance planning efficiency, especially on geographically extended railway networks with low accessibility.



The integration capabilities of TRC-4 systems with centralized traffic control (CTC), SCADA platforms, and industrial IoT environments also represent an essential technological breakthrough. Relay-based systems provide limited operational transparency because the state of the track circuit is generally represented only by the energized or de-energized condition of the track relay. In contrast, digital TRC nodes operate as intelligent cyber-physical devices capable of transmitting multidimensional operational data to higher-level control systems. This creates the foundation for centralized infrastructure analytics, remote diagnostics, and automated decision-support systems. In future intelligent railway architectures, such integration will enable direct interaction between signaling equipment, traffic management systems, and predictive maintenance platforms within unified digital ecosystems.

The introduction of machine-learning-based predictive diagnostics further increases the strategic value of digital TRC systems. By analyzing historical trends in ballast resistance, voltage stability, and signal attenuation, predictive algorithms can identify degradation processes long before they produce operational failures. Early identification of ballast deterioration, insulation breakdown, or asymmetrical current distribution allows maintenance teams to perform targeted preventive interventions, thereby reducing the probability of emergency failures and minimizing traffic disruptions. The practical implementation of anomaly-detection algorithms therefore transforms tonal rail circuits from passive safety devices into active diagnostic elements of intelligent railway infrastructure.

The economic implications of the transition to digital TRC systems are also highly significant. Although the initial capital expenditure for TRC-4 equipment is approximately 1.8 times higher than that of conventional TRC-3 installations, the reduction in operational expenditure compensates for the higher acquisition cost within several years of operation. Lower maintenance requirements, reduced energy consumption, fewer emergency repairs, and improved operational reliability collectively reduce total lifecycle costs. On heavily loaded freight corridors with intensive train traffic, the economic benefits become even more pronounced because signaling failures on such lines generate disproportionately high indirect losses associated with train delays, reduced throughput, and increased dispatching complexity.

### **Conclusion.**

This study presented a comprehensive technical and operational analysis of tonal rail circuits (TRC) as one of the key subsystems of modern railway automation and train interval control. The research integrated classical relay-based engineering principles with contemporary digital railway concepts, including SCADA integration, IoT-based monitoring, predictive maintenance, and Industry 4.0 approaches. Unlike previous studies that considered isolated technical aspects of TRC operation, the present work systematized the full set of interrelated engineering factors governing tonal rail circuit design and assessed their influence on reliability, safety, maintainability, and long-term modernization strategy.

The conducted analysis confirmed that the operation of tonal rail circuits is determined by seven interdependent design factors: the absence of isolating rail joints, cable parameter limitations, supplementary shunting zones, multi-circuit feeding from a common generator, cross-talk between same-frequency circuits, degradation under low ballast resistance, and the risk of unintended ALS code reception by following trains. These factors cannot be analyzed independently because any modification in one subsystem inevitably affects the electrical balance, impedance characteristics, and safety margins of adjacent track circuits. Consequently, the design of modern TRC systems requires a unified systems-engineering methodology that combines transmission-line modeling, adaptive impedance matching, frequency planning, and real-time diagnostic supervision.

The research demonstrated that the evolution from first- and second-generation tonal rail circuits toward third- and fourth-generation systems represents not merely a replacement of hardware elements but a transition to fundamentally different operational philosophy. Earlier TRC generations relied on isolated relay-based architectures with limited diagnostic capability and rigid configuration parameters. In contrast, modern digital TRC-4 systems incorporate programmable DSP-based signal processing, adaptive filtering, software-defined receiver sensitivity, and continuous telemetry exchange with centralized control systems. This transformation significantly improves operational resilience under unstable ballast conditions and reduces dependence on manual maintenance procedures.

The comparative analysis of TRC generations revealed several important technological trends. First, the progressive elimination of isolating rail joints reduced installation complexity and increased mechanical reliability of the rail infrastructure. Second, the expansion of operating carrier frequency ranges enabled more flexible frequency allocation and reduced electromagnetic interference risks. Third, the integration of generator, amplifier, and filtering modules into unified hardware platforms simplified equipment maintenance and reduced spare-part inventory requirements. Finally, the introduction of digital communication interfaces

enabled full integration of track circuits into intelligent railway infrastructure management systems.

The quantitative comparison between legacy TRC-3 systems and digitally integrated TRC-4 equipment demonstrated substantial operational advantages of digital architectures. According to the analyzed data, TRC-4 systems reduce false-clear indications by approximately 83 %, lower spontaneous false-occupancy events by up to 80 %, and decrease the mean time to fault detection from 12–18 minutes to less than 2 minutes. Equally significant is the extension of maintenance intervals from periodic three-month inspections to condition-based maintenance cycles reaching 12–18 months. Such improvements directly influence railway safety, line throughput, and maintenance economics, especially on high-density freight corridors.

The analysis also confirmed the importance of continuous ballast resistance monitoring as a central element of modern TRC reliability management. In conventional relay-based systems, ballast resistance deterioration is detected only during scheduled inspections, often after signaling performance has already degraded. Digital TRC-4 systems overcome this limitation through embedded impedance measurement circuits capable of real-time leakage conductance estimation. The resulting telemetry streams enable early detection of degradation processes caused by ballast contamination, moisture accumulation, or traction-current asymmetry. Continuous monitoring therefore transforms ballast resistance from a static design parameter into a dynamically supervised operational variable.

Particular attention was devoted to the integration of tonal rail circuits with SCADA platforms, PLC controllers, and IoT monitoring architectures. The study demonstrated that modern TRC systems can function as cyber-physical sensing elements within the intelligent railway ecosystem. Through secure digital interfaces, each TRC node continuously transmits operational parameters such as receiver voltage level, rail asymmetry coefficient, ballast conductance, relay state, and fault history to centralized supervisory systems. Such integration provides not only remote diagnostics but also the foundation for digital twins of railway infrastructure, enabling scenario-based simulation, traffic optimization, and predictive asset management.

The predictive maintenance analysis produced especially important results. Machine-learning algorithms trained on historical ballast resistance and signal-quality data demonstrated up to 92 % advance detection accuracy for developing infrastructure faults with a forecasting horizon of approximately 14 days. This represents a major shift from reactive or scheduled maintenance toward condition-based infrastructure management. The implementation of predictive diagnostics allows railway operators to reduce emergency failures, optimize maintenance crew deployment, minimize service interruptions, and improve lifecycle asset utilization. From an economic perspective, this transition significantly lowers operational expenditure despite the higher initial capital investment associated with digital TRC equipment.

The energy-efficiency assessment further confirmed the advantages of digital TRC architectures. The replacement of continuously energized relay circuits with low-power DSP-based electronics reduces average node power consumption by 35–45 %. On extended railway corridors, such reductions translate into substantial annual energy savings and contribute to broader sustainability goals within national railway modernization strategies. In the context of increasing attention to green transport and carbon reduction policies, the modernization of signaling infrastructure becomes relevant not only from a safety standpoint but also from an environmental and economic perspective.

From the standpoint of Kazakhstan railway modernization, the obtained results have important strategic implications. Freight-intensive corridors, including the Trans-Kazakhstan mainline network, require signaling systems capable of operating reliably under high traffic density, harsh climatic conditions, and variable ballast characteristics. The study confirms that digital tonal rail circuits satisfy these requirements more effectively than legacy relay-based systems. Moreover, their compatibility with ETCS-oriented architectures and centralized digital control systems aligns with the long-term objectives of the Kazakhstan Transport Strategy 2030 and international railway interoperability standards.

The research also identified several unresolved technical challenges requiring further investigation. Among them are adaptive frequency allocation methods under dynamically changing ballast conditions, advanced machine-learning models for early asymmetry detection in rail threads, and the development of standardized cybersecurity architectures for TRC telemetry networks. Additional research is also required in the field of software-defined signaling, where virtualized safety functions and cloud-based diagnostics may become feasible for future railway automation systems.

Another перспективное направление concerns the integration of TRC telemetry into unified railway digital twins capable of combining infrastructure condition monitoring, traffic management, and predictive maintenance within a single decision-support environment. Such integration could allow real-time simulation of train movements, automatic assessment of signaling reliability margins, and optimization of maintenance

schedules according to operational priorities. In the long term, tonal rail circuits may evolve from isolated signaling devices into distributed intelligent sensors forming part of a fully autonomous railway infrastructure ecosystem.

In summary, the performed study confirms that the transition from classical relay-based tonal rail circuits toward digitally integrated TRC systems constitutes a necessary and economically justified stage in the modernization of railway automation. The combination of adaptive signal processing, continuous monitoring, predictive analytics, and intelligent infrastructure integration significantly improves operational reliability, safety, maintainability, and energy efficiency. The obtained results may serve as a methodological and engineering foundation for future modernization programs on the railways of Kazakhstan and other CIS countries, while also contributing to the broader development of intelligent transport systems and Industry 4.0 railway technologies.

## REFERENCES

- Besekerskiy, 1978 – Besekerskiy, V.A. (1978). Sbornik zadach po teorii avtomaticheskogo regulirovaniia i upravleniia [Collection of problems in automatic regulation and control theory]. — M.: Nauka. 512 p. [In Russ.]
- Bryleev et al., 1984 – Bryleev, A.M., Pereburov, A.S., Sapozhnikov, V.V. (1984). Teoreticheskie osnovy zheleznodorozhnoi avtomatiki i telemekhaniki [Theoretical foundations of railway automation and telemechanics]. — M.: Transport. 398 p. [In Russ.]
- Chunyong Ma et al., 2020 – Chunyong Ma, Shengsheng Zhang, Anni Wang, Yongyang Qi, Ge Chen. (2020). Skeleton-based dynamic gesture recognition using an enhanced network with one-shot learning. Applied Sciences. Vol. 10. No. 11. 3680. <https://doi.org/10.3390/app10113680>. [In Eng.]
- IEC 62280:2014 – IEC. (2014). Railway applications — Communication, signalling and processing systems — Safety-related communication in railway systems (IEC 62280:2014). Geneva: IEC. 156 p. [In Eng.]
- Liukai et al., 2022 – Liukai Xu, Keqin Zhang, Genke Yang, Jian Chu. (2022). Gesture recognition using dual-stream CNN based on fusion of sEMG energy kernel phase portrait and IMU amplitude image. Biomedical Signal Processing and Control. Vol. 73. P. 103364. [In Eng.]
- Pereburov et al., 2018 – Pereburov, A.S., Sapozhnikov, V.V., Sapozhnikov, V.I. (2018). Diagnostirovanie ustroystv zheleznodorozhnoi avtomatiki, telemekhaniki i svyazi [Diagnostics of railway automation, telemechanics and communications equipment]. — M.: Uchebno-metodicheskii tsentr po obrazovaniiu na zheleznodorozhnom transporte. 172 p. [In Russ.]
- Podlipensky et al., 1995 – Podlipensky, V.S., Sabinin, Yu.A., Yurchuk, L.Yu. (1995). Elementy i ustroystva avtomatiki [Elements and devices of automatic systems] / Ed. Yu.A. Sabinin. Saint Petersburg: Politekhnik. 368 p. [In Russ.]
- Shishmarev, 2004 – Shishmarev, V.Yu. (2004). Tipovye elementy sistem avtomaticheskogo upravleniia [Typical elements of automatic control systems]. — M.: Akademiia. 320 p. [In Russ.]
- Sultangazinov, 2004 – Sultangazinov, S.K. (2004). Teoreticheskie osnovy avtomatiki i telemekhaniki [Theoretical foundations of automation and telemechanics]. — A.: Alla Prima. 286 p. [In Russ.]
- Sultangazinov et al., 2009 – Sultangazinov, S.K. (2009). Elementy ustroystv avtomatiki i telemekhaniki na zheleznodorozhnom transporte [Elements of automation and telemechanics devices on railway transport]. Almaty: Alla Prima. 151 p. [In Russ.]
- Sultangazinov et al., 2021 – Sultangazinov, S.K., Naurizova, N.Sh., Rustambekova, K.K. (2021). Telekomunikatsiinalyk zhelelderin quralzhabdygyn paidalaanu [Use of telecommunication network equipment]. — A.: IP Darkhan. 164 p. [In Kaz.]
- Sultangazinov, Rustambekova, 2022 – Sultangazinov, S.K., Rustambekova, K.K., Rustambekov, E.K. (2022). Elementy i stantsionnye sistemy zhd. transporta [Elements and station systems of railway transport]. — A.: IP Darkhan. 65 p. [In Russ.]
- Sultangazinov, Chukenova, 2024 – Sultangazinov, S.K., Chukenova, E.S. (2024). Sandyk skhimateknika zhane avtomattandyru qurylymdarynyng negizgi elementteri [Digital circuit engineering and basic elements of automation devices]. — A.: Salem. [In Kaz.]